

camera

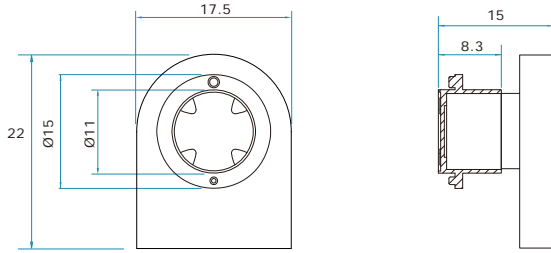

Body Type

Feature

- High Sensitivity!
- Low Light Performance.
- Easy to Hidden
- Easy install

optical panel(OP-100-01)/front

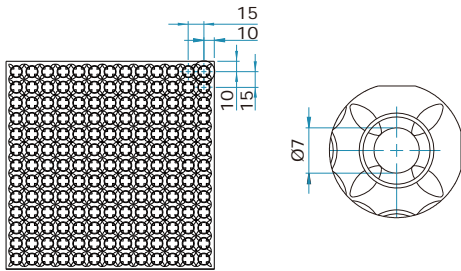

optical panel(OP-100-01)/rear

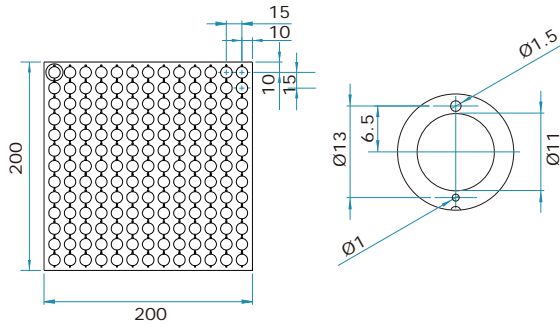

unit : mm (±0.5)

Specification

Model	MX-EZ55KS	MX-EZ57KS
Video system	NTSC / PAL	EIA / CCIR
Number of effective pixels	720 x 480 (NTSC/EIA & PAL/CCIR)	
Image sensor	4.86mm(1/3.7") CCIQIII color	4.86mm(1/3.7") CCIQIII B/W
Resolution(TV Lines)	480 TV Lines	550 TV Lines
S/N Ratio	47 [dB]	
Max Dynamic Range	63.3 [dB]	
Sensor scan mode	progressive scan	
Minimum illumination	0.03 Lux / 50IRE, 15 fps-LED turn off / 60cm 0.03 Lux / 140IRE, 15 fps-LED turn on / 60cm	
LED	sold separately: OPI-100S, OPI-100M	
Sensitivity	8.2[V/Lux.sec]	
Frame Rate	15 fps	
Horizontal sync frequency	NTSC/EIA -15.734kHz , PAL/CCIR - 15.625kHz	
Vertical sync frequency	NTSC/EIA - 60Hz , PAL/CCIR - 50Hz	
Video output	1Vp-p , 75ohm composite	
Lens	3.6mm / F2.0	
Storage temperature	-30 to 60 Degree C	
Working temperature	-10 to 45 Degree C	
Power source	Camera input: DC 5 - 12V	
Power current	160 mA(max)-DC12V	
Dimension (mm)	17.5 x 22 mm	



+



MO-EZ55KS, MO-EZ57KS

1. Hidden camera can be installed on any hole you drilled on the optical panel.

2. Optical panel can be cut into customized shape by customer request.

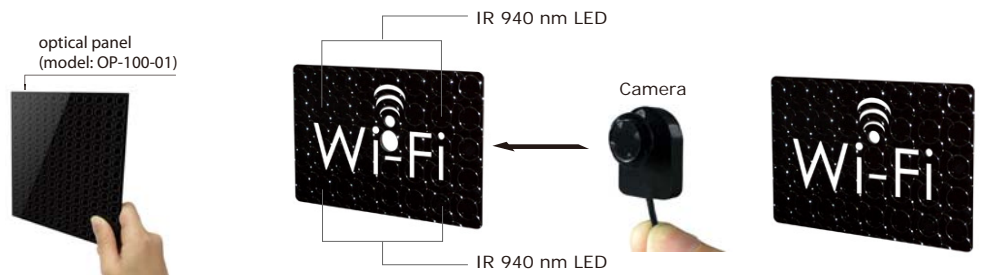

Body Type

	Model	NOTE	DIMENSION (mm)
<p>camera + optical panel (OP-100-01) 15fps (super low light)</p>	MX-EZ57KS	1/3.7" B/W CCIQ III SPY Hybrid Sensitivity Mini Concealed Camera kit	Camera: $\varnothing 15 \times 15$ mm Optical panel: 200 x 200 mm
	MX-EZ55KS	1/3.7" Color CCIQ III SPY Hybrid Sensitivity Mini Concealed Camera kit	
<p>15fps (super low light)</p>	MX-EZ57KSC	1/4" B/W CCIQ III SPY Hybrid Sensitivity Slim Concealed Camera	$\varnothing 15 \times 15$ mm
	MX-EZ55KSC	1/4" Color CCIQ III SPY Hybrid Sensitivity Slim Concealed Camera	
<p>camera + optical panel (OP-100-01) 15fps (super low light)</p>	MX-EZ57K	1/3.7" B/W CCIQ III SPY Hybrid Sensitivity Mini Concealed Camera kit	
	MX-EZ57KA	1/3.7" B/W CCIQ III SPY Hybrid Sensitivity Mini Concealed Camera kit + external microphone	
	MX-EZ55K	1/3.7" Color CCIQ III SPY Hybrid Sensitivity Mini Concealed Camera kit	
	MX-EZ55KA	1/3.7" Color CCIQ III SPY Hybrid Sensitivity Mini Concealed Camera kit + external microphone	
	MX-EZ59K	1/4" B/W CCIQ III SPY Hybrid Sensitivity Mini Concealed Camera kit	
	MX-EZ59KA	1/4" B/W CCIQ III SPY Hybrid Sensitivity Mini Concealed Camera kit + external microphone	
	MX-EZ56K	1/4" Color CCIQ III SPY Hybrid Sensitivity Mini Concealed Camera kit	
	MX-EZ56KA	1/4" Color CCIQ III SPY Hybrid Sensitivity Mini Concealed Camera kit + external microphone	
<p>15fps (super low light)</p>	MX-EZ57KC	1/3" B/W CCIQ III SPY Hybrid Sensitivity Mini Concealed Camera kit	
	MX-EZ55KC	1/3" Color CCIQ III SPY Hybrid Sensitivity Mini Concealed Camera kit	
	MX-EZ59KC	1/4" B/W CCIQ III SPY Hybrid Sensitivity CSM Mini Concealed Camera	
	MX-EZ56KC	1/4" Color CCIQ III Hybrid Sensitivity SPY CSM Mini Concealed Camera	
<p>camera + optical panel (OP-100-01)</p>	MO-EZ05	1/3" B/W CCIQ III SPY Mini Concealed Camera kit	Camera: $\varnothing 15 \times 18.8$ mm Optical panel: 200 x 200 mm
	MO-EZ05A	1/3" B/W CCIQ III SPY Mini Concealed Camera kit + external microphone	
	MO-EZ055	1/3" Color CCIQ III SPY Mini Concealed Camera kit	
	MO-EZ055A	1/3" Color CCIQ III SPY Mini Concealed Camera kit + external microphone	
<p>camera + optical panel (OP-100-01)</p>	MO-EZ06	1/4" B/W CCIQ III SPY CSM Mini Concealed Camera kit	Camera: $\varnothing 15 \times 8.8$ mm Optical panel: 200 x 200 mm
	MO-EZ06A	1/4" B/W CCIQ III SPY CSM Mini Concealed Camera kit + external microphone	
	MO-EZ066	1/4" Color CCIQ III SPY CSM Mini Concealed Camera kit	
	MO-EZ066A	1/4" Color CCIQ III SPY CSM Mini Concealed Camera kit + external microphone	
<p>15fps (super low light)</p>	MO-EZ05C	1/3" B/W CCIQ III SPY Mini Concealed Camera	$\varnothing 15 \times 18.8$ mm
	MO-EZ055C	1/3" Color CCIQ III SPY Mini Concealed Camera	
	MO-EZ06C	1/4" B/W CCIQ III SPY CSM Mini Concealed Camera	$\varnothing 15 \times 8.8$ mm
	MO-EZ066C	1/4" Color CCIQ III SPY CSM Mini Concealed Camera	
<p>OPC-100</p>	OPC-100	Optical camera cap only	$\varnothing 15$ mm / top $\varnothing 11$ mm
<p>OPI-100S</p>	OPI-100S	with IR 940nm LED	
<p>OP-100</p>	OP-100	Optical panel	200 x 200 mm
<p>OP-100-01</p>	OP-100-01	Optical panel -one hole drilled	200 x 200 mm
<p>OP-101-01</p>	OP-101-01	Optical panel -customized shape	
<p>OPI-100M</p>	OPI-100M	LED power control board with CDS function	